

FOD Linear Position and Displacement Sensor



The FOD is a fiber optic linear position and displacement sensor that provides high accuracy, absolute measurements of position and displacement. The FOD is well suited for difficult to reach locations and hazardous environments such as those containing explosive materials.

Features complete immunity to EMI and RFI, built-in safety for hazardous environments, high precision and high temperature operating range.

Research engineers in aerospace, defense, and different industrial areas may now improve process and product technology by monitoring the performance of specific properties over time that will provide accurate information on changes in displacement during the operation, the manufacturing process or throughout the lifetime of a product. The use of the FOD linear position and displacement sensor allows a complete analysis in the most challenging environments.

The FOD is an absolute position sensor and it is the fiber optic version of the well-known Linear Variable Differential Transformer (LVDT). However, unlike its electrically activated counterpart, the FOD requires no energizing AC voltage or driving signal with the associated wiring. Thus, the FOD is completely immune to EMI and RFI and carries no risk of current leakage or ignition. The FOD can be packaged in a very compact form and can be located up to 5 km away from the signal conditioner.

Our unique design is based on a Thin Film Fizeau Interferometer device (TFFI) mounted on a movable shaft. The TFFI acts as a spatially distributed Fabry-Perot cavity where the cavity length varies along the lateral position. The tip of an optical fiber faces the surface of the TFFI, which moves relative to the optical fiber extremity.

The FOD fiber optic linear position and displacement sensor combines all the desired characteristics you would expect in the ideal sensor. Its compact size, immunity to EMI/RFI, resistance to corrosive environments, high accuracy, and reliability make it the best choice for linear position and displacement measurements.

Key Features

- Intrinsically safe
- Immune to EMI/RFI
- Up to 170°C (338°F)
- Resolution of up to 0.002 mm
- 20 mm linear stroke
- Aluminum or composite material housing

Applications

- Microwave and RF environments
- In-situ process monitoring
- Harsh and hazardous environments
- High-temperature environments



Specifications

Linear stroke	20 mm (0.8 in)
Resolution¹	0.002 mm (0.00008 in)
Accuracy²	±0.02 mm (0.0008 in)
Connector type	ST connector
Operating temperature	-20°C to 170°C (-4°F to 338°F)

1. Signal conditioner dependent.
2. Calculated at calibration temperature using a fourth-order polynomial equation.

FOD Dimensions

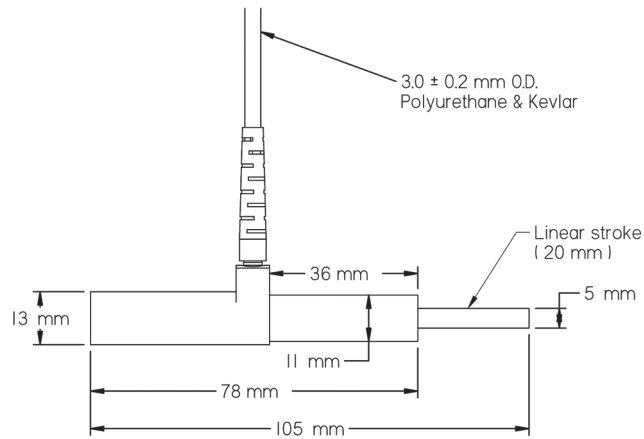

Drawing Number: SCH-00499