

Ø1.5" Cylindrical Laser Mount

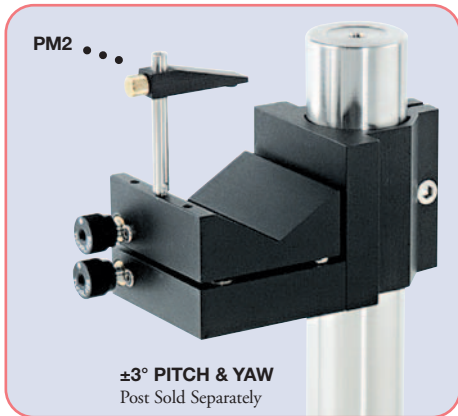

±3° PITCH & YAW
Post Sold Separately

- ±3° Pitch & Yaw Adjustment for Easy Beam Pointing
- Kinematic Design Provides Stability
- Ø2" (50mm) Maximum and Ø0.56" (14mm) Minimum Clamping Diameter
- Compatible With Standard Ø1.5" Mounting Posts

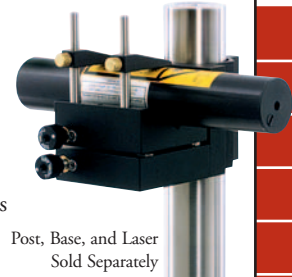

Post, Base, and Laser Sold Separately

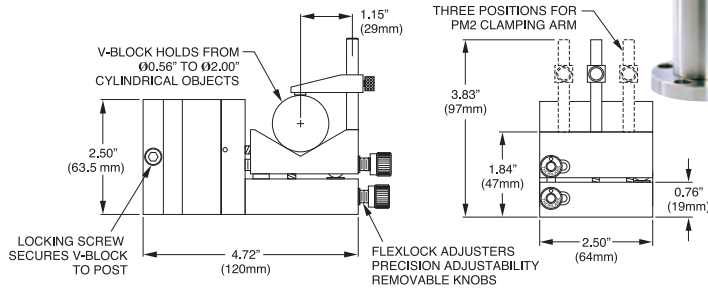

ITEM#	METRIC ITEM#	\$	£	€	RMB	DESCRIPTION
C1503	C1503/M*	\$221.00	£139.20	€205,50	¥2,110.60	Kinematic V-Clamp Mount
PM2	PM2/M	\$ 14.70	£ 9.30	€ 13,70	¥ 140.40	Large Clamping Arm

*One PM2 or PM2/M included with each unit.

The C1503 is a Kinematic V-Clamp Mount that provides two axes of precision angular adjustment. This clamp is ideal for mounting a HeNe laser or other large cylindrical objects. The angular adjustments provide control of the beam pointing, while the vertical height can be set by moving the unit along the support post (P-series Post). A series of hardened chromium steel balls and ball seats form a true kinematic mechanism that works with gravity and heavy-duty springs to provide long-term stability. Vertical positioning is achieved by sliding the rear clamping mechanism along the length of the Ø1.5" post. The clamping mechanism is actuated with a 3/16" (5mm) Allen key or balldriver.

Mounting Post V-Clamp

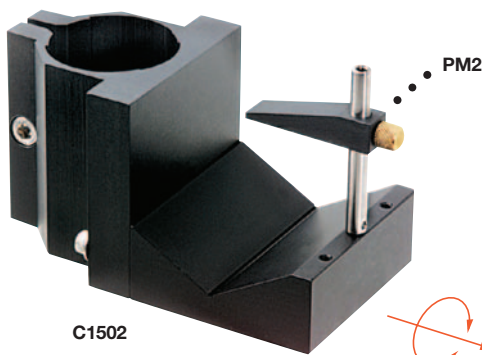

C1502

±10° Manual Pitch Adjustment

The C1502 will accept cylindrical objects ranging in diameters from Ø0.56" (14mm) to Ø2" (50mm). Each unit comes with one clamping arm (PM2); extra arms can be purchased separately (see below). The V-clamp can be manually adjusted within a ±10 degree range and then locked in place with two #8-32 (M4) socket head cap screws. Vertical positioning is achieved by sliding the rear clamping mechanism along the length of the Ø1.5" post. Once the desired vertical position is achieved the clamping mechanism is actuated with a 3/16" (5mm) Allen key or balldriver.

ITEM#	METRIC ITEM#	\$	£	€	RMB	DESCRIPTION
C1502	C1502/M*	\$ 92.00	£ 58.00	€ 85,60	¥ 878.60	Post V-Clamp Mount
PM2	PM2/M	\$ 14.70	£ 9.30	€ 13,70	¥ 140.40	Large Clamping Arm

*One PM2 or PM2/M included with each unit.

TOOLS OF THE TRADE

See Our HeNe Lasers Section, See Pages 570-574

New 17mW
632.8nm HeNe

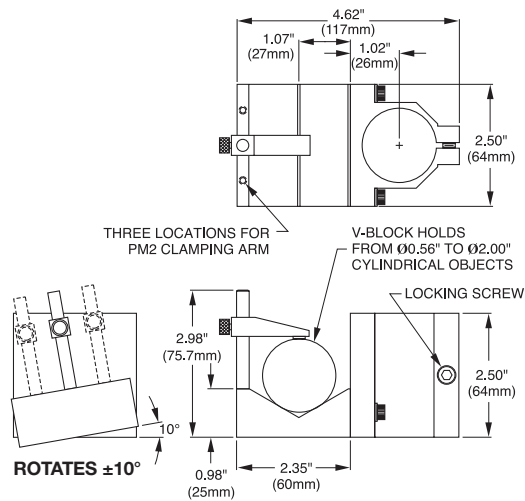

- Mounting Basics
- Optical Rails
- Mirror Mounts
- Lens Mounts
- Filter Mounts
- Rotation Mounts
- Adapters
- V-Mounts
- Apertures & Iris Diaphragms
- Lens Tubes
- Cage Systems