

AEROTECH AUTOMATION1



PWM Servo Drive with Motion Controller **Automation1 iXC2e**

Powerful PWM Drive & Full Motion Controller

Our high-performance, compact Automation1 iXC2e PWM servo motor drive with integrated motion controller is two solutions in one: it's capable of complete machine control and provides sub-nanometer levels of position control to linear or rotary servo motors, voice coil motors, stepper motors or any precision linear or rotary stage driven by one of these motor types. The silicon carbide (SiC) power amplifiers feature ultra-precise PWM switching, enabling excellent motor control performance.

The powerful Automation1-iSMC motion controller is loaded directly onto the same hardware that runs the drive, which in turn manages the trajectory of up to 12 axes of control over the HyperWire motion bus.

Automation1

The iXC2e is a part of the user-friendly Automation1 motion control platform, which includes the following:

- ◆ **Development Software**
- ◆ **Controls**
- ◆ **Motor Drives**
- ◆ **Fiber-Optic HyperWire® Communication Bus**

KEY FEATURES:

- ◆ Unlocks the full **MOTION CONTROL** power of our Automation1-iSMC intelligent software-based motion controller
- ◆ Features **COMPLETE CONFIGURATION & PERFORMANCE** capability of the XC2e PWM servo drive
- ◆ Includes local drive with **100 VDC BUS** motor power & up to **10 AMPS PEAK** output
- ◆ **ELIMINATES THE PC** from your control scheme
- ◆ Allows for up to **12 AXES OF CONTROL** when more Automation1 drives are connected over the HyperWire fiber-optic bus
- ◆ Includes PSO, the **ULTIMATE IN POSITION-BASED CONTROL** for industrial lasers, cameras & more
- ◆ Includes **SAFE TORQUE OFF (STO)** functional safety

AUTOMATION1 iXC2e CONTROLLER SPECIFICATIONS

SPECIFICATION	DESCRIPTION		
Motion Controller⁽¹⁾	Aerotech's Automation1-iSMC Intelligent Software-Based Motion Controller (version 2.2 and above)		
Maximum Axes of Control⁽¹⁾	Up to 12 axes		
I/O Points⁽¹⁾	See "I/O Expansion Board (-EB1)" specifications below. Note: Controller can control I/O from connected devices.		
Programming Language⁽¹⁾	AeroScript, RS-274 G-code		
APIs⁽¹⁾	<ul style="list-style-type: none"> • .NET (cross-platform Linux support) • C (cross-platform Linux support) • Python (cross-platform Linux support) • EPICS (cross-platform Linux support) see EPICS.anl.gov 		
Programming Tasks⁽¹⁾	4 user tasks (standard) / 9 user tasks (optional) 1 reserved task		
Position Modes	Absolute, incremental, dynamic trajectory correction		
Motion Types⁽¹⁾	<ul style="list-style-type: none"> • Linear motion • Clockwise & counterclockwise • Jogging • Homing • Rapid • Freerun • Many more 		
Acceleration Profiles	<ul style="list-style-type: none"> • Linear (time & rate based) • Sine (time & rate based) • S-curve (time & rate based) 		
Velocity Profiling⁽¹⁾	Yes		
Safe Zones⁽¹⁾	Yes		
Advanced Features⁽¹⁾	<table style="width: 100%; border: none;"> <tr> <td style="vertical-align: top; width: 50%;"> <ul style="list-style-type: none"> • Corner rounding • Tool normalcy control • Cutter compensation • Programmable fixture offsets⁽²⁾ • Rotation, mirroring & translation transformations • Part profile scaling • Polar & cylindrical transformations⁽²⁾ </td> <td style="vertical-align: top; width: 50%;"> <ul style="list-style-type: none"> • Orthogonality correction • Electronic gearing • EasyTune® & classical tuning • Backlash compensation • Spindle motion • High-speed registration • Multi-dimensional error mapping </td> </tr> </table>	<ul style="list-style-type: none"> • Corner rounding • Tool normalcy control • Cutter compensation • Programmable fixture offsets⁽²⁾ • Rotation, mirroring & translation transformations • Part profile scaling • Polar & cylindrical transformations⁽²⁾ 	<ul style="list-style-type: none"> • Orthogonality correction • Electronic gearing • EasyTune® & classical tuning • Backlash compensation • Spindle motion • High-speed registration • Multi-dimensional error mapping
<ul style="list-style-type: none"> • Corner rounding • Tool normalcy control • Cutter compensation • Programmable fixture offsets⁽²⁾ • Rotation, mirroring & translation transformations • Part profile scaling • Polar & cylindrical transformations⁽²⁾ 	<ul style="list-style-type: none"> • Orthogonality correction • Electronic gearing • EasyTune® & classical tuning • Backlash compensation • Spindle motion • High-speed registration • Multi-dimensional error mapping 		
Access Control	No		
Controller File System	Yes (5 GB)		
Supported HyperWire Drives	<table style="width: 100%; border: none;"> <tr> <td style="vertical-align: top; width: 50%;"> <ul style="list-style-type: none"> • Automation1-XC6e⁽³⁾⁽⁴⁾ • Automation1-XC4e⁽³⁾⁽⁴⁾ • Automation1-XC2e⁽³⁾⁽⁴⁾ • Automation1-XC4⁽³⁾⁽⁴⁾ • Automation1-XC2⁽³⁾⁽⁴⁾ </td> <td style="vertical-align: top; width: 50%;"> <ul style="list-style-type: none"> • Automation1-XR3⁽³⁾ • Automation1-XL5e⁽³⁾⁽⁴⁾ • Automation1-XL2e⁽³⁾⁽⁴⁾ • Automation1-SI4⁽³⁾ • Automation1-XI4⁽³⁾ </td> </tr> </table>	<ul style="list-style-type: none"> • Automation1-XC6e⁽³⁾⁽⁴⁾ • Automation1-XC4e⁽³⁾⁽⁴⁾ • Automation1-XC2e⁽³⁾⁽⁴⁾ • Automation1-XC4⁽³⁾⁽⁴⁾ • Automation1-XC2⁽³⁾⁽⁴⁾ 	<ul style="list-style-type: none"> • Automation1-XR3⁽³⁾ • Automation1-XL5e⁽³⁾⁽⁴⁾ • Automation1-XL2e⁽³⁾⁽⁴⁾ • Automation1-SI4⁽³⁾ • Automation1-XI4⁽³⁾
<ul style="list-style-type: none"> • Automation1-XC6e⁽³⁾⁽⁴⁾ • Automation1-XC4e⁽³⁾⁽⁴⁾ • Automation1-XC2e⁽³⁾⁽⁴⁾ • Automation1-XC4⁽³⁾⁽⁴⁾ • Automation1-XC2⁽³⁾⁽⁴⁾ 	<ul style="list-style-type: none"> • Automation1-XR3⁽³⁾ • Automation1-XL5e⁽³⁾⁽⁴⁾ • Automation1-XL2e⁽³⁾⁽⁴⁾ • Automation1-SI4⁽³⁾ • Automation1-XI4⁽³⁾ 		
Industrial Ethernet Communication	EtherCAT (Optional)		
Communication/Configuration Connection	<ul style="list-style-type: none"> • Ethernet • USB 		

Note:

1. See the [Automation1-iSMC](#) controller page for more information.
2. May require advanced programming.
3. Contains I/O on base drive.
4. Drive I/O expansion board option available.

AUTOMATION1 iXC2e GENERAL SPECIFICATIONS

CATEGORY	SPECIFICATION
Motor Style	Brush, brushless, voice coil, stepper ⁽¹⁾
Control Supply	24 VDC
Motor Supply	15-100 VDC
Bus Voltage ⁽²⁾	15-100 VDC
PWM Frequency	20 kHz
Peak Output Current (1 sec) ⁽³⁾	10 A _{pk}
Continuous Output Current ⁽³⁾	5 A
Position Synchronized Output (PSO)	Standard: One-axis PSO (includes one-axis Part-Speed PSO)* Optional: Two-axis PSO (includes two-axis Part-Speed PSO)* Two-axis Part-Speed PSO only* Three-axis Part-Speed PSO only* *Requires adding an expansion board to the drive to output PSO pulses via a physical connection.
25-Pin Motor Feedback Connector	High-speed differential inputs (encoder sin, cos & marker) CW and CCW limits Hall effect sensor inputs (A, B & C) Analog motor temperature input (accepts digital) Brake output
Multiplier Options	MX0 option: Primary encoder: 40 million counts per second square-wave input Auxiliary encoder: 40 million counts per second square-wave input MX2 option: Primary encoder: 2 MHz/450 kHz (bandwidth selectable) sine-wave input, encoder multiplier up to 65,536 Auxiliary encoder: 40 million counts per second square-wave input MX3 option: Primary encoder: 2 MHz/450 kHz (bandwidth selectable) sine-wave input, encoder multiplier up to 65,536 Auxiliary encoder: 450 kHz sine-wave input, encoder multiplier up to x16,384* *Encoders multiplied with this input cannot be echoed out
I/O Expansion Board (-EB1)	<ul style="list-style-type: none"> • 8x optically isolated digital inputs • 8x optically isolated digital outputs • 1x 16-bit differential, ±10 V analog input • 1x 16-bit single-ended, ±10 V analog input • PSO output connector with up to 12.5 MHz output rate
Drive Array Memory	67.1 MB (16,777,216 32-bit elements)
High Speed Data Capture	Yes (50 ns latency)
Safe Torque Off (STO)	Yes (SIL3/PLe/Cat 4)
HyperWire Connections	1x HyperWire small form-factor pluggable (SFP) port

Chart continued on next page

AUTOMATION1 iXC2e GENERAL SPECIFICATIONS

CATEGORY	SPECIFICATION
Automatic Brake Control	Standard (24 V at 0.5 A)
Absolute Encoder	Renishaw Resolute BiSS; EnDat 2.1; EnDat 2.2, and SSI
Current Loop Update Rate	20 kHz
Servo Loop Update Rate	20 kHz
Power Amplifier Bandwidth	2500 Hz maximum (software selectable)
Power Amplifier Efficiency	85-95% ⁽⁴⁾
Minimum Load Inductance	0.1 mH
Operating Temperature	0 to 40 °C
Storage Temperature	-30 to 85 °C
Weight	0.54 kg (1.20 lb.)
Compliance	CE approved, NRTL safety certification, EU 2015/863 RoHS 3 directive

1. For stepper motors only, one-half of bus voltage is applied across the motor (e.g., 80 VDC supply results in 40 VDC across stepper motor).
2. Output voltage dependent upon input voltage.
3. Peak value of the sine wave; RMS current for AC motors is 0.707 A_{pk}.
4. Dependent on total output power: efficiency increases with increasing output power.



AUTOMATION1 iXC2e ORDERING OPTIONS

Automation1-iXC2e

Automation1-iXC2e Automation1-iXC2e - Enhanced, Compact PWM Servo Drive with Motion Controller

Peak Current

-10 10 A peak, 5 A cont. current (default)

Expansion Board

-EB0 No expansion board (default)
-EB1 Expansion board with analog/digital I/O
-EB2 Expansion board with industrial Ethernet ports

Multiplier

-MX0 No encoder multiplier (default)
-MX2 x65536 multiplier (primary), no multiplier (auxiliary)
-MX3 x65536 multiplier (primary), x16384 multiplier (auxiliary)

PSO^(1,2)

-PSO1 One-axis PSO (includes one-axis Part-Speed PSO) (default)
-PSO2 Two-axis PSO (includes three-axis Part-Speed PSO)
-PSO5 Two-axis Part-Speed PSO
-PSO6 Three-axis Part-Speed PSO

1. PSO functionality is included in the base iXC2e. The -EB1 board is required to use PSO logic to generate an output signal.

2. Encoder feedback-based PSO requires the -MX0 multiplier option.

AUTOMATION1 PS2 DIN RAIL POWER SUPPLY ORDERING OPTIONS

Automation1-PS2

Automation1 PS2 Automation1-PS2 - Din-rail mounted power supply for 1 to 4 compact servo drives

Drive Type (Required)

-D1 PS2 for XC2, XC2e drives & iXC2e, iXC2 drive-based controllers
-D2 PS2 for XL2e drives & iXL2e drive-based controllers

Power Output (Required)

-P1 240 watts at 24 VDC
-P2 240 watts at 48 VDC
-P3 480 watts at 48 VDC
-P4 480 watts at 96 VDC
-P5 240 watts at +/-12 VDC (10A)
-P6 240 watts at +/-24 VDC (5A)
-P7 480 watts at +/-48 VDC (5A)

Number of Axes (Required)

-AX01 1 axis of wiring
-AX02 2 axes of wiring
-AX03 3 axes of wiring
-AX04 4 axes of wiring

AUTOMATION1 iXC2e DIMENSIONS

AUTOMATION1 iXC2e, -EB0 OPTION

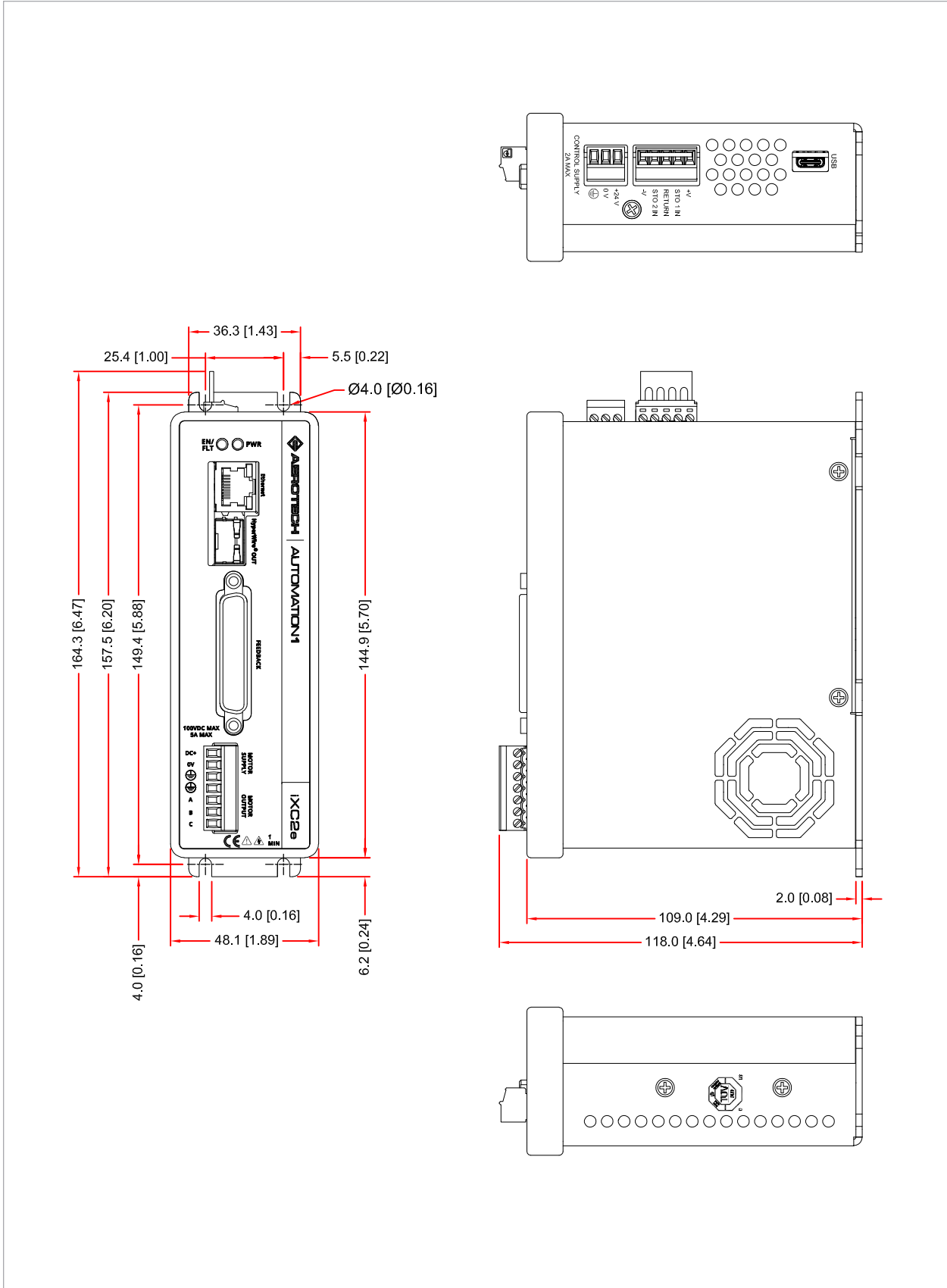

AUTOMATION1 iXC2e DIMENSIONS

AUTOMATION1 iXC2e, -EB1 OPTION

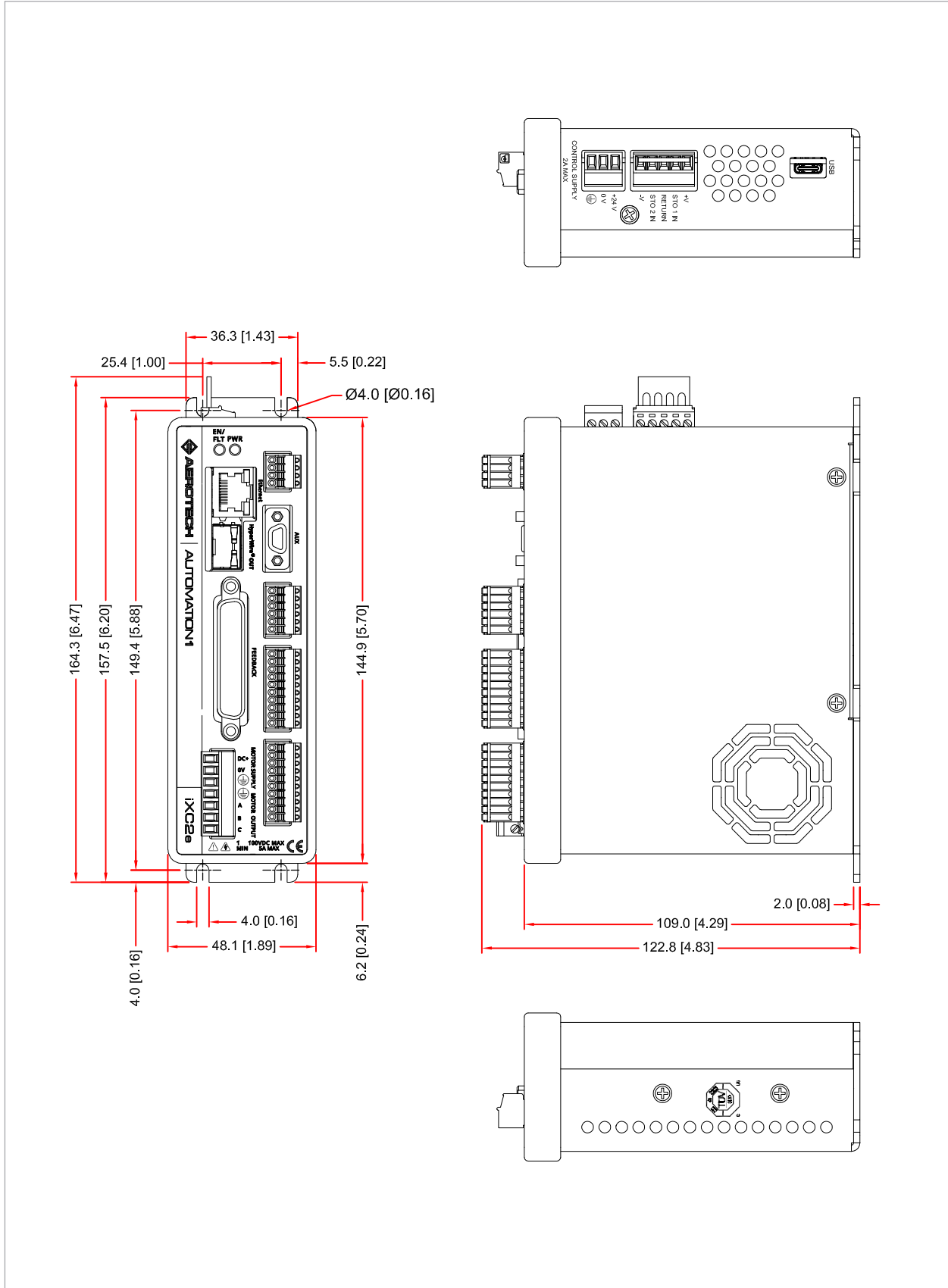

AUTOMATION1 iXC2e DIMENSIONS

AUTOMATION1 iXC2e, -EB2 OPTION

